



201.40



201.80

Congratulations!

On choosing this FUTECH instrument. FUTECH provides measuring instruments of precision and quality. Contributions from professional end users enable us to offer innovative, easy-to-use equipment.

DISTY40 / DISTY80
Distance meter

IMPORTANT!

Read the instructions for use carefully before using the instrument. Keep them in a safe place for consultation when necessary.







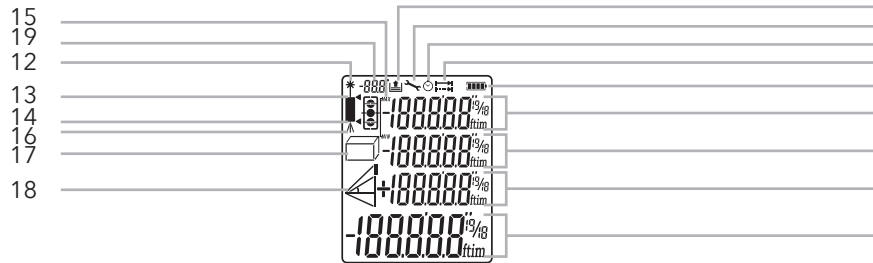

Whether on or off, keep the instrument out of reach of children.

This equipment is a high quality precision instrument which must be handled with care. Avoid shocks and vibration. After use, always replace the instrument in its carrying bag. Make sure that the bag and instrument are dry; otherwise condensation may occur in the device. Make sure that the windows are free of dirt, and clean them using a soft cloth and a glass cleaning product only. Always use the locking device during transportation. Regularly inspect the accuracy of the instrument, especially when starting any major square-setting work. You have sole responsibility for the accuracy of your work. Do not use any optical equipment such as a magnifying glass to view the laser beam, and take care to remove all reflecting objects to avoid damage to the eye. Locate the laser in such a way that it is not possible for any person to look at the laser beam (intentionally or otherwise). Under no circumstances take the instrument apart, since this may expose you to powerful laser radiation. The laser is only to be used for the projection of laser lines. Do not use the instrument in rain or near flammable materials. Technical modification or alterations to the instrument may be carried out without prior notice. The manufacturer's responsibility shall in no case exceed the value of the costs of repair or replacement of the instrument. Respect the environment and do NOT discard the instrument or batteries in household waste. Take them to a recycling centre.

DISTY40 / DISTY80

MANUAL



1. Display
2. On / DIST (on / measuring)-button
3. Timer
4. Tilt-functions
5. Function-button
6. Plus-function
7. Minus-function
8. Memorybutton
9. Referencepoint
10. Beep / Units
11. Delete / Off - button
12. Laser active
13. Referencepoint in front
14. Referencepoint at the back
15. Reference point positioning bracket
16. Max. and Min.-measurement
17. Surface  / Volume 
18. Indirect measurement
 - Single pythagoras 
 - Double pythagoras 
 - Double pynth. (half height) 
 - Tilt-function ,  of 
19. Digital waterlevel / record number
20. Memorysymbol
21. Error-symbol
22. Timer
23. Single / continue measurement
24. Battery
25. Intermediate line 1
26. Intermediate line 2
27. Intermediate line 3
28. Summary line

Start-up

Inserting / replacing batteries

- Remove battery compartment lid and attach handstrap.
- Insert batteries, observing correct polarity
- Close battery compartment again.

Note

Only use alkaline or rechargeable batteries
Remove the batteries before a long period of non-use to avoid the danger of corrosion

Changing the reference point (multifunctional endpiece)

The instrument can be adapted for the following measuring situations:

- For measurements from an edge, fold out the positioning bracket until it first locks in place. (corner of 90°)
- For measurements from a corner, open the positioning bracket until it locks in place, then push the positioning bracket lightly to the right to fold it out fully.

Menu functions

Measurements

-button (pressed long) - Press once again to change the unit of distance measurement. The following units are available: m (meter), ft (feet), in (inch), ft +/- in (feet - inch 1/16)

Beep

 button (press long). You can choose the beep on or off as required.

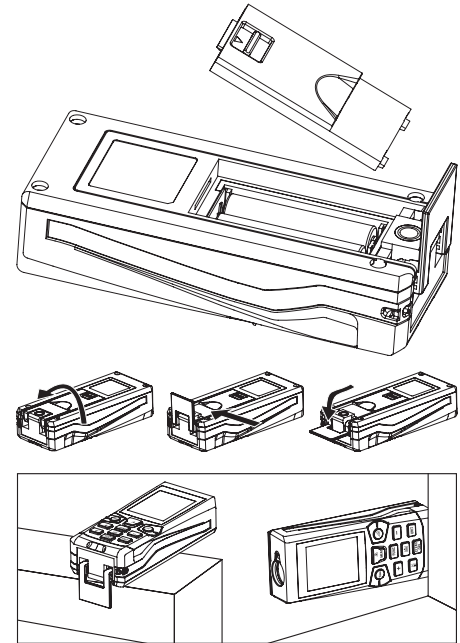



Measuring with tripod

The reference must be appropriately adjusted in order to be able to take correct measurements with a tripod. You can switch the reference by -button. The setting can be shown on the display.

Operation

Switching on and off



Switches on the instrument and laser by using the -button. Pressing the -button for longer switches the instrument off. The laser will be deactivated after 30 seconds of inactivity, the device after 3 minutes.



Clear button

Pressing the -button, the last action is cancelled. While making area of volume measurements, each single measurements can be deleted and remeasured in series.

Reference

The default reference setting is from the rear of the instrument. The display will show you .

Press the -button to change the reference point to the forefront. The display will show you .

Press the -button again to change the reference point again to the rear. The display will show you .

The reference point can also be moved to the point of the positioning bracket when it is unfolded 180°. This can be done with the -button, but only when it is unfolded. The display shows .



Tilt-function

For some measuring functions the inclination of the device can be used to calculate the result. Use the -button to activate this function.

(Available for single pythagoras, double pythagoras, double pythagoras with partial height).

Measuring

Single distance measurement

Press  to activate the laser. Press  again to trigger the distance measurement. The result is displayed immediately.

Minimum/maximum measurement

This function allows the user to measure the minimum of maximum distance from a fixed measuring point. It can also be used as to determine spacings. It is commonly used to measure room diagonals (maximum values) or horizontal distances (minimum values).

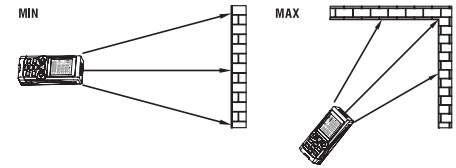

Press the -button and hold down this button until you hear a beep. Then slowly sweep the laser back and forth and up and down over the desired target point (e.g. into the corner of a room).

Press the -button to stop continuous measurement. The values for maximum and minimum distances are shown in the display as well as the last measured value in the summary line.





Addition / Substraction

Push the  to do a distance measuring

- Use the -button to add a measurement to the previous one. This process can be repeated as required.
- Use the -button to subtract a measurement to the previous one. This process can be repeated as required.
- Use the -button to cancel the last step.

Surface



Press once the **FUNC**-button. The  symbol appears in the display.

- Press the -button to take the first measurement (e.g. length)
- Press the -button to take the second measurement (e.g. width).

The result is displayed in the summary line.

Volume

Press twice the **FUNC**-button. The  symbol appears in the display.

- Press the -button to take the first measurement (e.g. length)
- Press the -button to take the second measurement (e.g. width).
- Press the -button to take the third measurement (e.g. height).

The result is displayed in the summary line.

If you press after the volume measurement for a longer time, extra measured values will appear on the display.

- total surface of ceiling / floor *
- total wall area *
- total perimeter of the floor *
- volume

* assuming a room with straight walls / ceiling / floor without obstacles.

Tilt measurement

The tilt-sensor is activated activate by default when the device is switched on. You can activate or deactivate the function by pushing . The number of degrees of the slope are shown at the top of the screen.

Indirect measurement

The instrument can calculate distances using Pythagoras' theorem.

Make sure you adhere to the prescribed sequence of measurement:

- All target points must be in a horizontal or vertical plane.
- The best results are achieved when the instrument is rotated about a fixed point (e.g. with the position bracket fully folded out and the instrument placed on a wall).
- The minimum/maximum measurement can be used. The minimum value must be used or measurements at right angles to the target; the maximum distance for all the other measurements.

Make sure that the first measurement and the distance to be measured are at right angles. Use the minimum/maximum function, as explained in "Measuring → Minimum/maximum measurement".

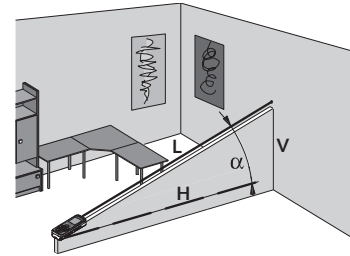

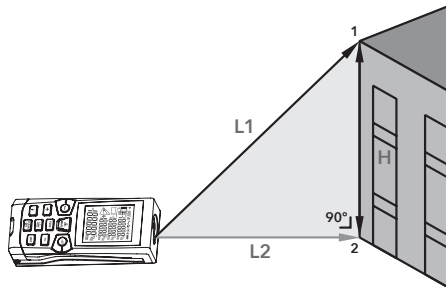

- **Indirect measurement - (single pythagoras)**

Press the **FUNC**-button once, the display shows the \sphericalangle -symbol. The laser is switched on. The distance to be measured flashes in the symbol visible on the screen. Aim at the upper point and trigger the measurement using **MEASURE**. Then carry out the second horizontal measurement. After the measurement, the results are shown on the display. The measured distance (slope) is shown on the top line, the measured horizontal side on the second link. The calculated height on the third line.

Keep in mind that the length of the horizontal line is only 100% correct when a precise vertical measurement is performed.

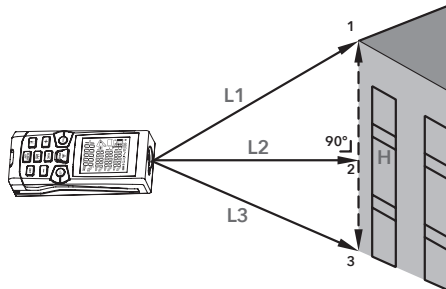

- **Double indirect measurement - (double pythagoras)**

Press the **FUNC**-button twice; the display shows the \sphericalangle -symbol. The laser is switched on. The distance to be measured flashes in the symbol visible on the screen. Aim at the upper point and trigger the measurement using **MEASURE**. Then perform the second (90°) and third measurement. The results are now shown on the screen (from top to bottom)

- distance to upper point
- distance from the measured horizontal point
- distance to lower point
- distance between upper and lower point (height)

• **Double indirect measurement - (double pythagoras - partial height)**

Press the **FUNC**-button twice; the display shows the \sphericalangle -symbol. The laser is switched on. The distance to be measured flashes in the symbol visible on the screen. Aim at the upper point and trigger the measurement using **MEASURE**. Then perform the second and third (90°) measurement. The results are now shown on the screen (from top to bottom)

- distance to first, upper point
- distance to the second point
- distance from the measured horizontal point
- distance between first, upper point and the second point (height)

Storage of constants/historical storage

Press the **MEMO**-button short, the symbol will be displayed. The last measured value appears on the display. The previous 99 results (measurements of calculated results) are shown in reverse order.

The **+** and **-** buttons can be used for navigation.

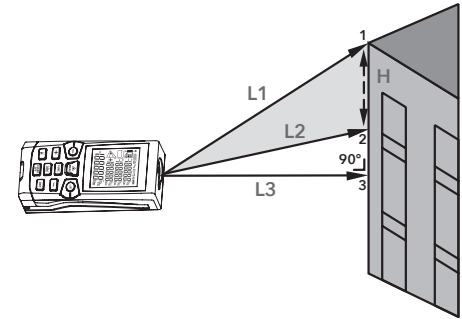

Appendix

Message codes

CODE	REASON	SOLUTION
204	CALCULATION ERROR	PERFORM THE MEASUREMENT AGAIN
208	RECEIVED SIGNAL TOO WEAK, TOO LONG MEASURING TIME, DISTANCE TOO LARGE	USE A TARGET PLATE
209	RECEIVED SIGNAL TOO STRONG	REFLECTION OF THE GOAL IS TOO GREAT. USE A TARGET IMAGE
252	TEMPERATURE TOO HIGH	LET THE INSTRUMENT COOL DOWN
253	TEMPERATURE TOO LOW	WARM UP THE INSTRUMENT
255	HARDWARE ERROR	SWITCH THE DEVICE ON AND OFF SEVERAL TIMES. IF THE MESSAGE CONTINUES TO APPEAR, THE DEVICE MAY BE DEFECTED. CONTACT YOUR DEALER.

Measuring conditions

Measuring range

The Disty40 is limited to 40m, the Disty80 to 80m. At night or dusk and if the target is in shadow, the measuring range without target plate is increased. Use a target plate to increase the measurement range during daylight or if the target has poor reflection properties.

Target surfaces

Measuring errors can occur when measuring toward colourless liquids (e.g. water) or dust free glass, Styrofoam or similar semi-permeable surfaces. Aiming at high gloss surfaces may deflect the laser beam and lead to measurement errors. Against non-reflective and dark surfaces the measuring time may increase.

Care

Do not immerse the instrument in water. Wipe off dirt with a damp, soft cloth. Do not use aggressive cleaning agents or solutions. Handle the instrument as you would a telescope or camera.

GENERAL

Description

The following directions should enable the person responsible for the product, and the person who actually uses the equipment, to anticipate and avoid operational hazards. The person responsible for the product must ensure that all users understand these directions and adhere to them.

Adverse Use

- Use of the product without instruction.
- Use outside of the intended limits.
- Disabling safety systems.
- Removal of hazard notices.
- Opening the product using tools, for example screwdriver, unless this is specifically permitted for certain functions.
- Modification or conversion of the product.
- Use after misappropriation.
- Use of products with obviously recognizable damages or defects.
- Use with accessories from other manufacturers without the prior explicit approval of FUTECH.
- Inadequate safeguards at the work site, for example when using on or near roads.
- Deliberate dazzling of third parties.
- Controlling of machines, moving ob-

jects or similar monitoring application without additional control and safety installations.

WARNING

Adverse use can lead to injury, malfunction and damage. It is the task of the person responsible for the equipment to inform the user about hazards and how to counteract them. The product is not to be operated until the user has been instructed on how to work with it.

LIMITS OF USE

Environment

Suitable for use in an atmosphere appropriate for permanent human habitation: not suitable for use in aggressive or explosive environments.

DANGER

Local safety authorities and safety experts must be contacted before working in hazardous areas, or in close proximity to electrical installations or similar situations by the person in charge of the product.

RESPONSIBILITIES

Manufacturer of the product

Laseto N.V., Belgium, BE0808.043.652, hereinafter referred to as FUTECH, is responsible for supplying the product, in-

cluding the user manual and original accessories, in a completely safe condition.

Manufacturers of non FUTECH accessories

The manufacturers of non FUTECH accessories for the product are responsible for developing, implementing and communicating safety concepts for their products, and are also responsible for the effectiveness of those safety concepts in combination with the FUTECH product.

Person in charge of the product

The person in charge of the product has the following duties:

- To understand the safety instructions on the product and the instructions in the user manual.
- To be familiar with local regulations relating to safety and accident prevention.
- To inform FUTECH immediately if the product and the application becomes unsafe.

HAZARDS OF USE

WARNINGS

- The person responsible for the product must ensure that it is used in accordance with the instructions. This person is also accountable for the training and the deployment of personnel who use the product and for the safety of the equipment in use.
- The absence of instruction, or the inadequate imparting of instruction, can lead to incorrect or adverse use, and can give rise to accidents with far-reaching human, material, financial and environmental consequences.
- All users must follow the safety directions given by the manufacturer and the directions of the person responsible for the product.
- Watch out for erroneous measurement results if the product has been dropped or has been misused, modified, stored for long periods or transported.
- Periodically carry out test measurements and perform the field adjustments indicated in the user manual, particularly after the product has been subjected to abnormal use and before and after important measurements.
- If the product is used with accessories, for example masts, staffs, poles, you may increase the risk of being struck by lightning.
- Do not use the product in a thunderstorm.
- Inadequate securing of the working site can lead to dangerous situations, for example in traffic, on building sites, and at industrial installations.
- Always ensure that the working site is adequately secured. Adhere to the regulations governing safety and accident prevention and road traffic.
- If the accessories used with the product are not properly secured and the product is subjected to mechanical shock, for example blows or falling, the product may be damaged or people may sustain injury.
- When setting-up the product, make sure that the accessories are correctly adapted, fitted, secured, and locked in position. Avoid subjecting the product to mechanical stress.
- During the transport, shipping or disposal of batteries it is possible for inappropriate mechanical influences to constitute a fire hazard.
- Before shipping the product or disposing of it, discharge the batteries by running the product until they are flat. When transporting or shipping batteries, the person in charge of the product must ensure that the applicable national and international rules and regulations are observed. Before transportation or shipping contact your local passenger or freight transport company.
- High mechanical stress, high ambient temperatures or immersion into fluids can cause leakage, fire or explosions of the batteries.
- Protect the batteries from mechanical influences and high ambient temperatures. Do not drop or immerse batteries into fluids.
- Short circuited battery terminals can overheat and cause injury or fire, for example by storing or transporting in pockets if battery terminals come in contact with jewellery, keys, metallized paper or other metals.
- Make sure that the battery terminals do not come into contact with metallic objects.
- During the operation of the product there is a hazard of squeezing extremities by moving parts.
- Keep extremities in a safe distance from the moving parts. If the product is improperly disposed of, the following can happen: If polymer parts are burnt, poisonous gases are produced which may impair health. If batteries are damaged or are heated strongly, they can explode and cause poisoning, burning, corrosion

or environmental contamination. By disposing of the product irresponsibly you may enable unauthorized persons to use it in contravention of the regulations, exposing themselves and third parties to the risk of severe injury and rendering the environment liable to contamination.

- The product must not be disposed with household waste. Dispose of the product appropriately in accordance with the national regulations in force in your country.

LASER CLASSIFICATION

General

The following directions (in accordance with the state of the art - international standard IEC 60825-1(2007-03) and IEC TR 60825-14 (2004-02)) provide instruction and training information to the person responsible for the product and the person who actually uses the equipment, to anticipate and avoid operational hazards. The person responsible for the product must ensure that all users understand these directions and adhere to them.

Products classified as laser class 1, class 2 and class 3R do not require:

- laser safety officer involvement,
- protective clothes and eyewear,

- special warning signs in the laser working area if used and operated as defined in this user manual due to the low eye hazard level. Products classified as laser class 2 or class 3R may cause dazzle, flash blindness and afterimages, particularly under low ambient light conditions.

DECLARATION OF CONFORMITY

We herewith declare that this product conforms with the following standards and directives:

Standards

EN 61326-1:2013
EN 61326-2-2:2013

in accordance with the regulations stipulated in the directives:

EC Directive

2014/30/EU (Electromagnetic Compatibility Directive)



Technical changes reserved. We accept no liability for printing errors.

All images, explanations or technical specifications can be updated without prior notice.

DISTY40 / DISTY80

MANUAL

FUTECH instruments are made with carefully selected components and crafted with the utmost care. By that, we can offer you an optimal quality. If your device should however be defective due to faulty materials or a production error, you can benefit from a 2 years manufacturer's warranty.

During this period, your instrument will be repaired or replaced for free if following conditions are met:

1. Your device has been purchased less than two years ago from an authorized FUTECH distributor. Please provide a copy of the invoice that indicates the type and the serial number of your faulty device.
2. You deliver the faulty device to an authorized FUTECH distributor in its original protective packaging (pouch in fabric, plastic suitcase ...).
3. The device shows no damage caused by incorrect usage (eg. Crack(s) from a fall, internal water damage, fuses melted by the use of an inappropriate charger or adapter, battery leakage, device opened by a non-authorized technician, ...)

The manufacturer's warranty does not include periodic maintenance works (eg. Annual adjustments) nor the included batteries.

FUTECH is a registered trademark of LASETO N.V. in Belgium (BE 0808 043 652) available at www.futech-tools.com.

TECHNICAL SPECIFICATIONS

	DISTY40	DISTY80
MEASURING RANGE	0,05 TO 40M	0,05 TO 80M
MEASURING ACCURACY	± 2MM	
MEASURING UNITS	M / INCH / FT	
LASER CLASSIFICATION	CLASS II	
LASER TYPE	635NM, <1 MW	
DISTANCE MEASUREMENT WITH TILT SENSOR	✓	
HORIZONTAL MEASUREMENT RANGE	±90°	
HORIZONTAL MEASUREMENT ACCURACY	±0,5°	
AREA, VOLUME MEASUREMENT	✓	
INDIRECT MEASUREMENT	✓	
PYTHAGORAS PROPOSITION	✓	
PLUS-MUNUS METHOD	✓	
CONTINUOUS MEASUREMENT	✓	
MINIMUM/MAXIMUM MEASUREMENT	✓	
DISPLAY ILLUMINATION	✓	
SHOW BEEP	✓	
MULTIFUNCTIONAL END PIECE	✓	
PROTECTION AGAINST SPLASHES AND DUST	IP54	
HISTORICAL STORAGE	99	
TEMPERATURE RANGE OF OPERATION	-10°C TO 50°C	
TEMPERATURE RANGE OF STORAGE	-20°C TO 60°C	
BATTERY LIFE	UP TO 4000 MEASUREMENTS	
BATTERIE SELECTION	TYOE AAA - 2X 1,5V	
LASER SWITCH-OFF AUTOMATICALLY	AFTER 30 SECONDS	
INSTRUMENT SWITCH-OFF AUTOMATICALLY	AFTER 3 MINUTES	
DIMENSIONS	115 X 48 X 29MM	
WEIGHT	0,11KG (WITHOUT BATTERY)	



JOIN US

 Facebook
@futechtools

 LinkedIn
futech-tools

 World Wide Web
futech-tools.com

